

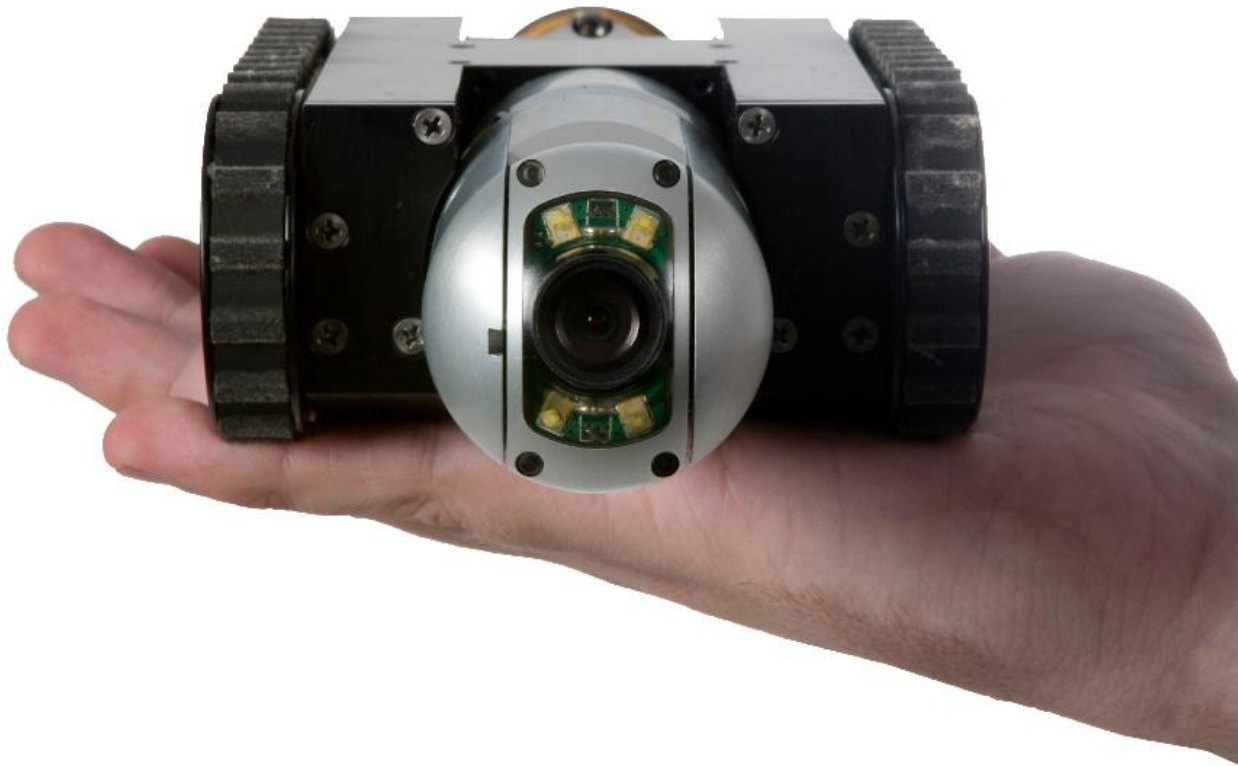

Eddyfi Robotics Inc
2569 Kenworth Road, Suite C
Nanaimo, BC, V9T 3M4
CANADA

+1.250.729.8080
info@eddyfitechnologies.com
www.eddyfitechnologies.com



INUKTUN NANOMAG™

Table of Contents

About This Manual.....	4
System Description.....	4
Specifications.....	5
Certification.....	5
Safety.....	6
System Setup.....	8
Personnel Requirements.....	8
Working Environment.....	8
System Power.....	8
Power Requirements.....	8
Generators / Inverters.....	9
Controller Setup.....	9
Connections.....	9
Operation.....	10
Tether Handling.....	10
Vehicle Configuration.....	11
Changing a Track Belt.....	11
Magnet Installation and Removal.....	12
Rear Camera Installation.....	14
Operation.....	15
Pre-Operations Inspection.....	15
Post-Operations Inspection.....	15
Controller Operation.....	15
Maintenance.....	16

Fuse Replacement	16
Spectrum 45™ Camera Maintenance	16
Troubleshooting.....	16
Parts and Repairs.....	17
Ordering Parts/Customer Service	17
Warranty Repairs	17
Factory Returns to Canada.....	17
Product/System Drawing Package Availability	18
Limited Warranty Policy	18

About This Manual

This manual has been prepared to assist you in the operation and maintenance of your Eddyfi Technologies' Inuktun equipment. Correct and prudent operation rests with the operator who must thoroughly understand the operation, maintenance, service and job requirements. The specifications and information in this manual are current at the time of printing.

This product is continually being updated and improved. Therefore, this manual endeavors to explain and define the functionality of the product. Furthermore, schematics or pictorials and detailed functionality may differ slightly from what is described in this manual.

Eddyfi Technologies reserves the right to change and/or amend these specifications at any time without notice. Customers will be notified of any changes to their equipment.

Information in this manual does not necessarily replace specific regulations, codes, standards, or requirements of others such as government regulations.

This manual copyright © 2019 by Eddyfi Robotics Inc. All rights reserved.

System Description

The Inuktun NanoMag™ crawler is a custom video inspection vehicle for confined spaces. The vehicle features a worm-drive crawler platform with front and rear color cameras. Both cameras have their connections made in the center cross section of the frame and are mounted low between the tracks giving the vehicle an overall height of 50 mm (2 in). The tether has a length of 30 m (100 ft) and is terminated inside the left rear frame portion where it also is restrained. The vehicle is equipped with up to 10 disc magnets that can be found at the bottom of the vehicle behind two retainer plates. This allows the vehicle to crawl up and down a steel wall in any direction and operate completely inverted on a reasonably smooth surface.

The NanoMag crawler features an integrated Spectrum 45™ Pan and Tilt camera with fully variable high intensity LEDs and the ability to focus at objects as close as 10 mm (0.39 in). In addition to the front camera, the crawler has an integrated rear Sapphire™ camera for observing the tether and objects behind the vehicle.

Document: UMAM000196	Revision: B02	Created by: JS	Date: 27 Jul 2020	IPN: 3024835-B02
Source Location: C:\ePDM\ISLEng\products\am-nanomag\manuals\UMAM000196.docm				Page 4 of 18

Specifications

Min Vehicle Dimensions		224 x 105 x 50 mm (8.8 x 4.1 x 2.0 in)
Vehicle Weight ¹		2.3 kg (5 lb)
Depth Rating		Not Rated
Maximum Tether Length ²		30 m (100 ft)
Tracks	Internally Integrated	2.5 m/min (8 fpm)
Camera	Front	Spectrum 45™
	Rear	Sapphire™
Power Requirements		100 – 240 VAC 50/60Hz, 5A
Operating Temperature		0 – 50 °C (32 – 122 °F)
Storage Temperature		-20° – 60 °C (-4 – 140 °F)

¹ Weights may vary depending on optional components

² Actual travel distance may be decreased depending on inspection geometry (traction and number of bends)



Certification

The NanoMag™ system is built in accordance with the Low Voltage Directive 2014/35/EU, Machinery Directive 2006/42/EC, and Electromagnetic Compatibility Directive 2014/30/EU.





Safety



In order to be able to use this product properly and safely, every user must first read these operating instructions and observe the safety instructions contained therein. Take care of these operating instructions and keep them in a place where they can be accessed by everyone. Untrained personnel should not handle or operate this equipment.



	CAUTION: Failure to follow these safety instructions may result in injury or equipment damage.	
---	---	---

This system includes some specific devices that have their own User Manuals. Instructions on those manuals must be also read before using the system.

 <p>CAUTION Interaction with metallic objects may produce Pinch Hazards. Persons with Medical Implants KEEP BACK 12 inches.</p> <p>Strong Magnetic Field</p>	<p>WARNING: Magnetic Pinch Hazard – The magnetic chassis is fitted with rare earth magnets. These magnets are very strong and create an imminent pinch hazard. Use caution when handling the magnets or vehicle near steel objects and tools, they may snap together unexpectedly.</p>
	<p>WARNING: Medical Hazard – Operators with magnetically sensitive medical implants should be aware of and follow appropriate practices.</p>
	<p>WARNING: Electronic Device Interference – Magnetically sensitive devices, including computer hard drives, cell phones, watches and credit cards may be disrupted or damaged by the magnetic field.</p>
	<p>Note: Rare earth materials are mechanically weak, and magnetically very strong. They must therefore be handled very carefully to avoid damage.</p>

	Note: To reduce risk of injury and damage to equipment, always store the NanoMag™ magnetic vehicle in its magnetically shielded storage and shipping box or store the magnets on a steel plate when not in use.	
---	--	---

	Note: We strongly recommend using gloves when handling the vehicle to reduce magnetic pinching hazard.	
---	---	---

	Warning: Avoid Magnetic Slamming. Extreme care must be taken when handling the vehicle, particularly when placing it onto a wall or into its storage box. Without taking heed of the sudden pull of the magnetic field onto surface, the NanoMag™ can be slammed down hard causing damage to the vehicle.	
---	--	---



WARNING: Intense Optical Radiation - The Spectrum 45™ camera lights are extremely bright. Never look directly at the lights. Use a welding filter (shade #8 or higher) if inspecting the LEDs.

- When performing maintenance or functional checks of the lasers and camera lights, take precautions to protect nearby personnel from unintended exposure which could be temporarily blinding.
- Observe safe lifting practices. For storage and shipping, the NanoMag system is packed in two parts: Controller and Vehicle. Each of the two components is either built or packed into a Pelican case with carrying handle.
- Do not operate the system with damaged wires. A short circuit may damage the power system, telemetry system, cameras, or attached equipment. Exposed wires may also create a shock hazard.
- Disconnect the power source before servicing the product; otherwise, damage may result.
- Although designed for durability, the vehicle and its components or attached devices may suffer structural damage if dropped or impacted. A lifeline or fall arrest system should be used at all time when the vehicle is navigating on a vertical or inverted horizontal position. In addition, stepping on the tether may pull the vehicle off the wall causing it to fall and sustain physical damage.
- All personnel operating or maintaining this equipment must be trained and competent.
- Eddyfi Technologies equipment is used in many varied environments from hot/dry to confined spaces to deep underwater. Such diverse environment risks must be addressed by the operators who are trained to work in such surroundings. As such, the operator is responsible to determine safe site setup and appropriate personal protective equipment (PPE) for operation and maintenance of the equipment.



WARNING: Spark Hazard - Under no circumstances should this equipment be used in a potentially explosive atmosphere



WARNING: Trip Hazard - Never stand on the tether. A snap load to the tether may pull it out from underneath you and cause you to fall. Standing on the tether may also damage its internal conductors, cause unnecessary wear, and decrease its life. Stepping on the tether may also pull a magnetic vehicle off the wall.



WARNING: High Temperature - The camera head may become hot during operation. Allow a cool-down period before handling.



WARNING: Mechanical Pinch Hazard – Rotating or moving components can draw fingers into a pinch position. Do not handle the vehicle while mobile parts are running, turn off power or disconnect the tether while reconfiguring or maintaining the vehicle.

System Setup

Personnel Requirements

Basic deployment of the NanoMag system may be performed by one person. Operations at more complex worksites may require two people, especially when the console location is removed from the point of deployment.

- **Console Operator:** This person is responsible for driving the vehicle, watching the pipe and making comments about the location and pipe condition. It is also the operator's responsibility to assess whether a pipe is in the appropriate condition for safe passage of the vehicle or if there is a risk of getting stuck. The operator may also assist in general site setup (cones, warning signs, etc.), vehicle maintenance and configuration.
- **Deployment / Tether Handler / Field Maintenance:** This person has several tasks including:
 - Configuring the vehicle for the current pipe
 - Lowering the vehicle in and out of the manhole
 - Watching the tether as the vehicle enters and exits the pipe
 - Operating the reel and winding the tether during recovery

Establish a good channel of communication between the operator and deployment personnel. Good communication can avoid accidents, damage to the equipment, and promotes efficiency and productivity. In particular, the person deploying the vehicle and watching the tether must be able to quickly tell the operator to stop the vehicle if something goes wrong. The operator should never turn on power or initiate movement without first communicating with the vehicle handler.

Working Environment

The NanoMag system is to be used in a dry, covered environment only. The controller, tether and vehicle are not waterproof. Keep all cords and cables away from water.

Recommended operating temperatures are between 0 – 50 °C (32 – 122 °F).

System Power

Power Requirements

The NanoMag is operated through a Versatrax™ controller. The controller provides power to the tether and vehicle.

Power Input: 100 – 240 VAC, 50/60 Hz, 5A

Document: UMAM000196	Revision: B02	Created by: JS	Date: 27 Jul 2020	IPN: 3024835-B02
Source Location: C:\ePDM\ISLEng\products\am-nanomag\manuals\UMAM000196.docm				Page 8 of 18

Generators / Inverters

If powering the system from a generator or inverter, refer to that unit's operating manual for recommendations on continuous and peak load ratings. These power sources may apply a reduced output rating based on electrical load and environmental temperature. Remember to include the power needs of any other connected devices (external monitors, recording devices, lighting, etc.) when selecting a generator or inverter.

Controller Setup

The NanoMag vehicle is designed to be powered and operated using the Versatrax™ control system. Refer to the Versatrax controller manual on how to properly set up the controller.

Connections

To connect the NanoMag system to the Versatrax controller, do the following:

1. Locate the connector panel at the side of the controller. It should be covered with a black cover plate. Depress the black push button and slide the cover forward to remove.



2. Connect the power cord to **AC POWER**
3. Connect the vehicle tether to **TETHER** – *Note the three keys along the connector's circumference and make sure to align these with the mating connector keyways*
4. External monitors may be connected with an RCA connector as follows:
 - a. **RAW VIDEO** – Front camera feed without overlay
 - b. **OVERLAY VIDEO** – Front camera feed with overlay
5. An external keyboard may be connected to the **KEYBOARD** port

Note that AUX VIDEO, LINE VOLTAGE, WINCH ENCODER, DESKTOP CONTROLLER, FACTORY TEST and LINE VOLTAGE select are not used with this system.

Document: UMAM000196	Revision: B02	Created by: JS	Date: 27 Jul 2020	IPN: 3024835-B02
Source Location: C:\ePDM\ISLEng\products\am-nanomag>manuals\UMAM000196.docm				Page 9 of 18

Operation

Once the vehicle has been connected to the controller, power it on and make the following configuration changes. See the Versatrax™ controller manual for full operational instructions.

Several controller options are required for proper operation of the NanoMag. These are:

- Pan / Tilt Speed must be set to **AUTO**.
- Track Reversal must be set to **LEFT**.
- Track Type must be set to **NANOMAG**.
- Chassis Type must be set to **PARALLEL**.

A number of Versatrax controller functions are not used with the NanoMag system and can be ignored. These are:

- Encoder Functions
- In-Line Chassis Configuration
- Master/Slave Mode
- Pan & Tilt Camera Feedback
- Zoom
- Aux Lights Control Knob

Tether Handling

The tether is one of the most important parts of the system. It feeds power and control signals to the system and returns data to the controller. If the tether is damaged from improper use, poor handling or an accident, the system may become inoperable. This could lead to significant downtime, loss of production, and avoidable costly repairs. It is encouraged to stress the importance of the tether and its use to anyone operating or maintaining the system. For maximum tether life and reliability, we recommend the following tether handling tips.

- Do not step on the tether
- Do not drive over the tether
- Do not bend the tether beyond its minimum bend radius
- Do not kink the tether
- Do not snap load the tether
- Avoid loading the tether whenever possible
- Always use the cable grip strain relief if applicable to your system
- Regularly inspect the tether for damage
- Regularly clean the tether

Note: Protecting the conductors inside the tether is critical to the life and operation of the tether. Proper tether handling and care will result in extended tether life and system reliability.

Vehicle Configuration

Changing a Track Belt

The NanoMag can be outfitted with either a low-profile belt for magnetic operation, or with a deep lug belt for non-magnetic operation.

To change the track belt, do the following:

1. Remove 6x #6-32 x 1/4 in FHMS from the idler wheel cover and remove the cover – ***note that these screws are special low-profile head screws***
2. Loosen the idler tensioning screw
3. Slip the belt off the idler wheel
4. Install the new belt
5. Tension the new belt by pulling forward on the idler wheel and then tightening the tensioning screw
6. Re-install the idler wheel cover – use Loctite 243 on the 6 cover screws

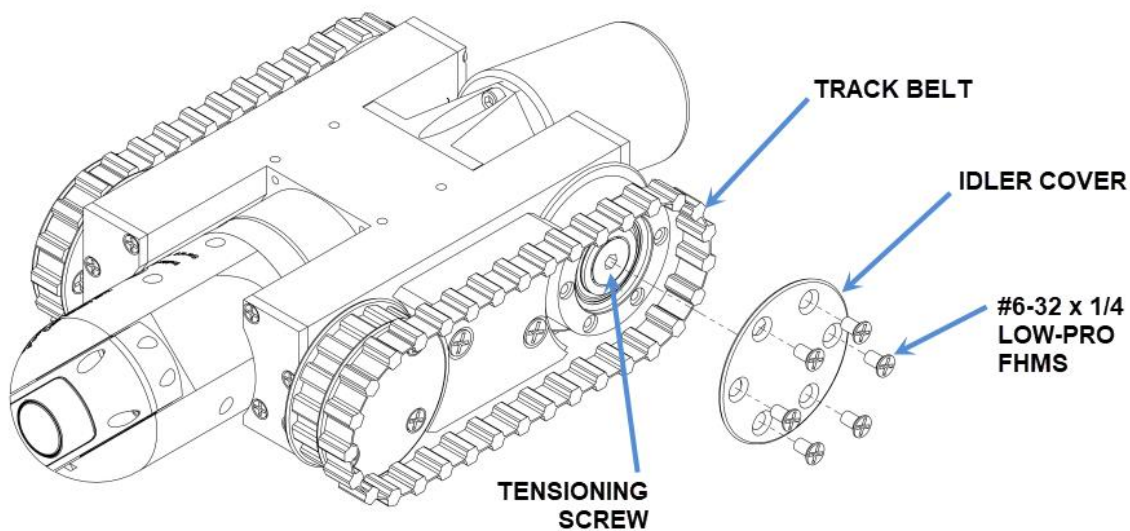

Document: UMAM000196	Revision: B02	Created by: JS	Date: 27 Jul 2020	IPN: 3024835-B02
Source Location: C:\ePDM\ISLEng\products\am-nanomag>manuals\UMAM000196.docm				Page 11 of 18

Magnet Installation and Removal

The magnetic strength of the vehicle can be varied by adding or removing magnets.

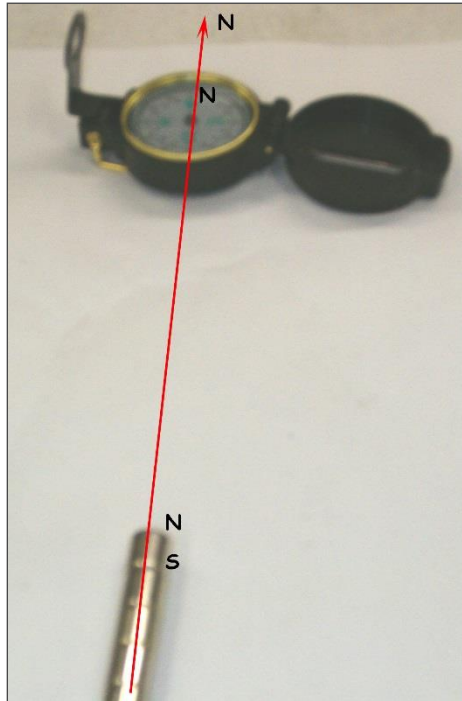

1. Determine North and South of each individual or entire stack of magnets. Refer to the photograph above
2. Using a compass, align it with the magnets as show. The south pole on the compass will point to the north pole of the magnets
3. Mark the stack with an 'N' and an 'S' accordingly
4. Mark each magnet with a black dot at the 'North' position

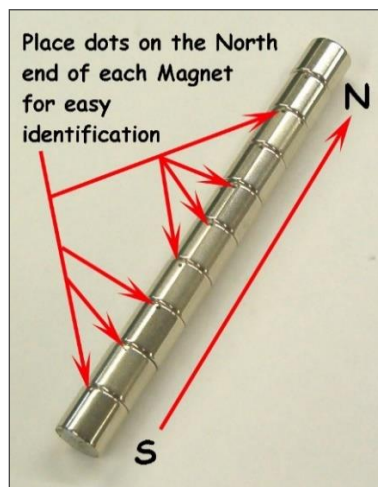

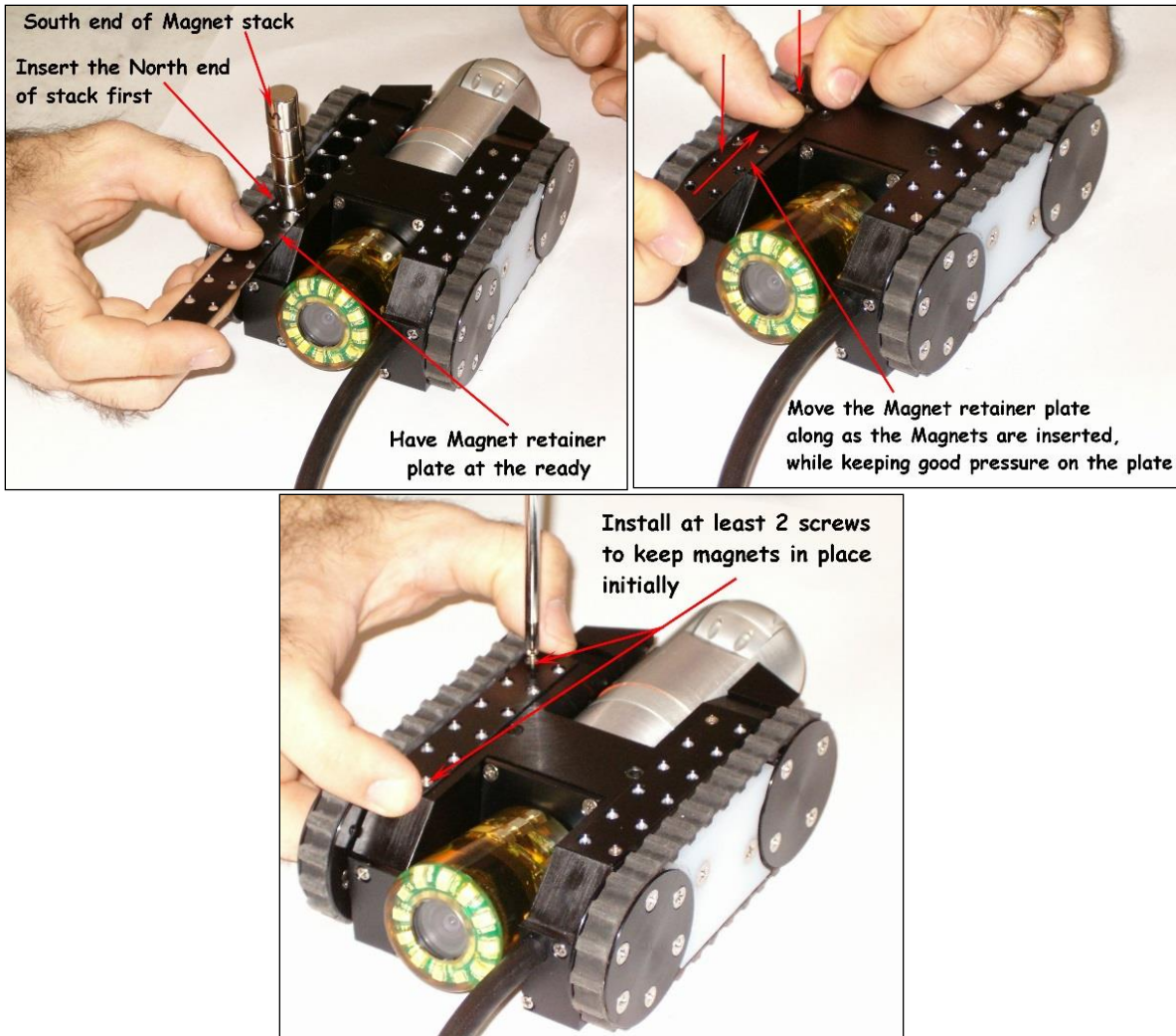

5. Follow the photographs above for the insertion of magnets. To remove magnets, reverse the procedure.



WARNING: Pinch Hazard - These magnets are very powerful. When removing the screws from the magnet retainer plate, maintain good pressure on the plate. Failing to do so will allow the magnets to jump out and could easily pinch or cut your fingers.

Rear Camera Installation

To install the rear camera:

1. Attach the mounting plate to the camera with 1x #6-32 X 3/4 in SHCS using the bottom hole only – note the TOP indicator on the camera.
2. Attach the micro-fit connector from the camera to the vehicle.
3. Attach the plate and camera to the vehicle using 2x #6-32 X 3/8 in SHCS into the vehicle, and 1x #6-32 x 3/4 in SHCS into the camera.

Removal is the reverse of installation. If the camera is removed, install a blanking plate with 4x #6-32 X 3/8 in SHCS as shown below.

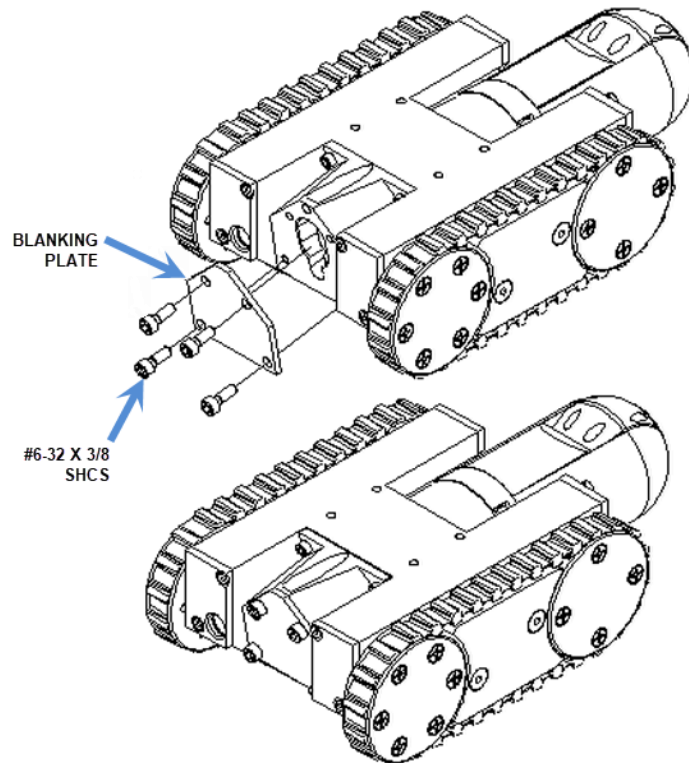
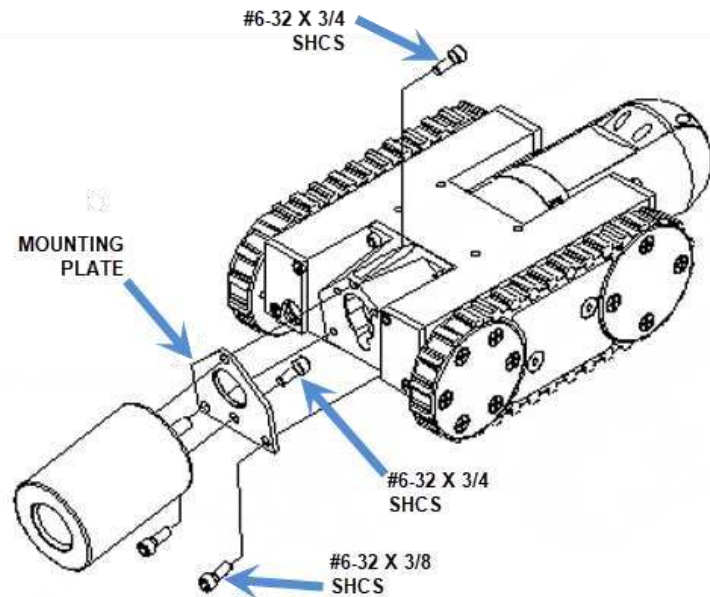

Operation

Pre-Operations Inspection

Before each mission:

1. Ensure that all fasteners are in place and secure.
2. Check all the controller connections.
3. Check that there is no mechanical damage to the vehicle and tether.
4. Power up the system and test each function to ensure proper operation before sending it on its mission.
5. Check that the Vehicle Type is set to NANOMAG.



WARNING: System Damage - Vehicle type must always be set to **NANOMAG** to prevent motor damage (The NanoMag™ motors run at 24 VDC max but could be sent up to 48 VDC if this is set incorrectly).

Post-Operations Inspection

At the conclusion of each mission:

1. Visually inspect the vehicle for damage or entrained debris.
2. Test each function to ensure proper operation.
3. If the mission is totally complete, power down the system.
4. Clean the system and store it properly in a dry environment for next use – *do not wash!*



CAUTION: Do not use a use water to was the vehicle as it is not splash proof or depth rated. Wipe down with a damp rag or alcohol.

Note: If the NanoMag is put away in good working order, deployment time is minimized the next time the vehicle is needed.

Controller Operation

Refer to the Versatrax™ controller manual for controller setup and operating instructions.

Note: The portable controller routes rear (AUX) video directly to the built-in monitor and recorder. Consequently, the Auxiliary Video jack on the portable controller is disabled.

Document: UMAM000196	Revision: B02	Created by: JS	Date: 27 Jul 2020	IPN: 3024835-B02
Source Location: C:\ePDM\ISLEng\products\am-nanomag>manuals\UMAM000196.docm				Page 15 of 18

Maintenance

Fuse Replacement

The controller and power supply contain panel mount fuses for both AC and DC voltages. These fuses are for the safety of the operator(s) as well as to protect the equipment from damage. If a fuse blows, stop and look for possible causes. Causes might include cable damage, water incursion or improper connections. *See the controller manual for fuse replacement.*

Fuse values have been carefully selected for their application. Always replace the fuses with the same type and rating.



Caution: Disconnect the power source before checking or replacing fuses.

Spectrum 45™ Camera Maintenance

Refer to the Spectrum 45 camera manual for care and maintenance instructions.

Troubleshooting

Refer to the troubleshooting guide at the back of the Versatrax™ controller manual.

Document: UMAM000196	Revision: B02	Created by: JS	Date: 27 Jul 2020	IPN: 3024835-B02
Source Location: C:\ePDM\ISLEng\products\am-nanomag>manuals\UMAM000196.docm				Page 16 of 18

Parts and Repairs

Ordering Parts/Customer Service

Spare and/or replacement parts are available for your product and can be ordered directly from your local office.

When ordering parts, always make sure to quote the sales order acknowledgement (SOA) number and/or the serial number of the system component in question.

Eddyfi Robotics Inc. (Canadian Headquarters and Manufacturing Location)

2569 Kenworth Road, Suite C

Nanaimo, BC, V9T 3M4

CANADA

TF 1.877.468.5886

T +1.250.729.8080

info@eddyfi.com

www.eddyfitechnologies.com

Eddyfi Technologies – US (American Authorized Distributor and Service Centre)

812 W 13th Street

Deer Park, TX, 77536

USA

T +1.281.542.3292

info@eddyfi.com

www.eddyfitechnologies.com

Warranty Repairs

Warranty conditions are specified in the Warranty section. Should any conditions of the manufacturer's warranty be breached, the warranty may be considered void. All returned items must be sent prepaid to Eddyfi Technologies at the above address.

Factory Returns to Canada

Some sub-assemblies of your Eddyfi Technologies product are not field-serviceable and may need to return to the factory for repair. Warranty claims must return to the factory for evaluation.

To return an item for evaluation or repair, first contact Eddyfi Technologies at our toll-free number or e-mail address. Eddyfi Technologies will supply a Return Merchandise Authorization (RMA) number with detailed shipping and customs instructions. Items shipped without an RMA number will be held at Eddyfi

Document: UMAM000196	Revision: B02	Created by: JS	Date: 27 Jul 2020	IPN: 3024835-B02
Source Location: C:\ePDM\ISLEng\products\am-nanomag\manuals\UMAM000196.docm				Page 17 of 18

Technologies until the correct paperwork is completed. If cross-border shipments are not labelled as per the instructions, the items may be held by customs and issued additional fees.

All returned items must be sent prepaid unless other specific arrangements have been made.

When the product or system is being shipped anywhere by courier or shipping company, it must be packaged in the original packaging it was received in. This measure greatly reduces the consequences of rough handling and subsequent shipping damage.

Eddyfi Technologies cannot be held responsible for damages due to improper packaging. Shipping damage may have significant impact on repair turnaround times.

Product/System Drawing Package Availability

Mechanical assembly and electrical wiring diagram drawing packages for your equipment are available in PDF format upon request. Printed copies may also be purchased from Eddyfi Technologies. Contact your local sales contact for more information.

Limited Warranty Policy

Refer the Eddyfi Technologies website for warranty terms for this product.
<https://www.eddyfi.com/en/salesterms>

Document: UMAM000196	Revision: B02	Created by: JS	Date: 27 Jul 2020	IPN: 3024835-B02
Source Location: C:\ePDM\ISLEng\products\am-nanomag>manuals\UMAM000196.docm				Page 18 of 18